

System LSI for Public Displays

MN81010H

■ Overview

“MN81010H” is a system LSI for public displays that features a variety of interfaces and delivers multi-purpose digital signage solutions.

It supports multi-screen configurations, is network compatible, and can be used to efficiently develop public display products in varying configurations.

■ Features

- The built-in high-performance CPU (ARM CA9) and high-performance GPU (OpenGL ES2.0) deliver a wide range of effects and quick response with a high-speed graphics rendering.
- A vast range of content playback is supported. For example, content playback over the network and various media playback (USB etc.) are supported.
- Multi-screen compatibility allows expansion to arrays of up to 10 x 10 panels. In order that the multiple panels look seamlessly as a single screen, it is possible to adjust individually the size/ position and chromaticity/ brightness of the displayed image in each panel.
- Since many peripherals are incorporated, systems can be built with the minimum amount of external components.

■ Applications

“MN81010H” is well-suited to a wide range of display products, including multi-screen displays and digital signage devices.

Multi-screen displays



- Large screen displays up to 10 x 10 panels
- Enables seamless, natural images

Digital signage devices



- Low-cost, space-saving interactive signage
- Features include eye-catching video effects

■ Specifications

Function		Specifications
Package		BGA / 21mm x 21mm / 0.8mm pitch
CPU		ARM CA9 800MHz (2,000 DMIPS)
Graphics		OpenGL ES2.0
Memory		DDR3-1333 (16bit) x2
AV Decoder		On the air / Network
Demodulator		ATSC, QAM, DVB-T/C, ISDB-T/S
Standby Microcontroller		Build-in
I/O	Ethernet	Build-in MAC + PHY
	USB	USB2.0-HS x3
	HDMI Input	Ver1.4a x4 *One port supports ARC.
	Analog Video Input	CVBS, YC, YPbPr, VGA
	LVDS Output	LVDS / mini-LVDS (60Hz)
Video Processor	HQ Picture	High quality IP convertor and Noise reducer Super-resolution
	FRC	No
	TCON	Yes (60Hz)

■ System Configuration(Example)

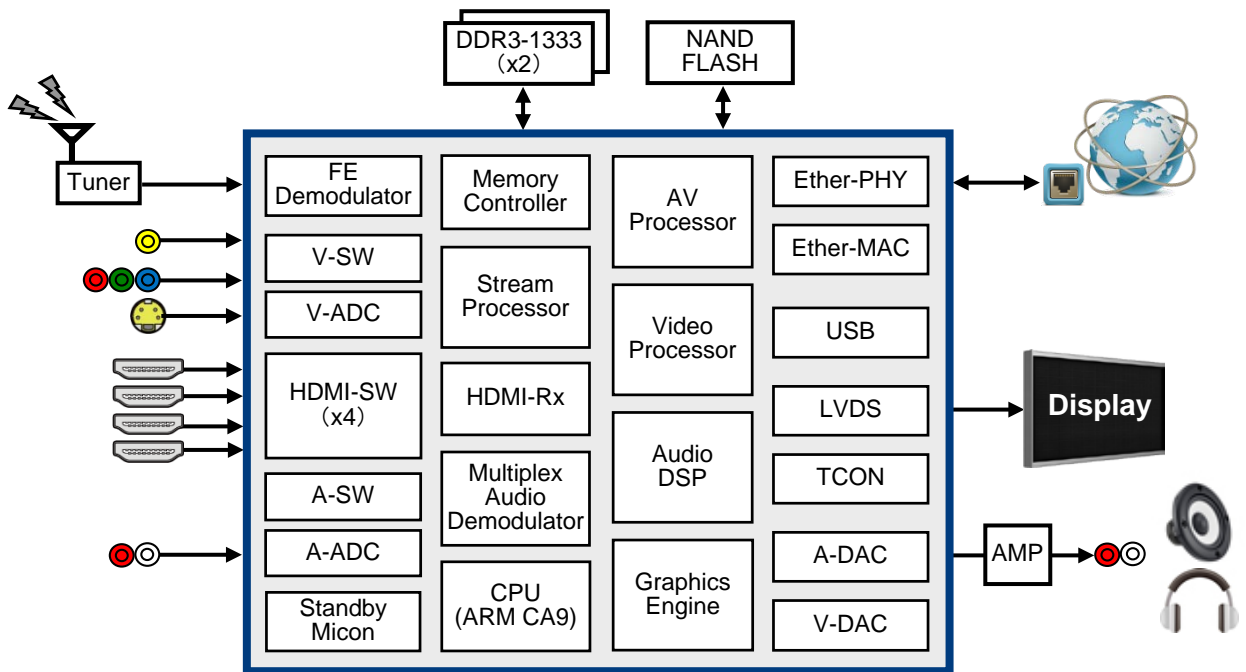

The Products and product specifications described in this document are subject to change without notice for modification and/or improvement. At the final stage of your design, purchasing, or use of the products, therefore, ask for the most up-to-date Product Standards in advance to make sure that the latest specifications satisfy your requirements. All company names, brand names and trademarks herein are property of their respective owners.

Copyright 2016 Socionext Inc.
AD04-00079-1E March 2016
Edited : Visual System Business Unit

Socionext Inc.

Nomura Shin-Yokohama Bldg.,
2-10-23 Shin-Yokohama,
Kohoku-ku, Yokohama, Kanagawa, 222-0033, Japan
Tel. +81-45-568-1015
<http://socionext.com>